

1		2		3		4		5		6	
Document No.	QR4-700-T-003	REV.	A/0	REV.	DESCRIPTION	REVISOR	DATE	APPROVED			
				0		Hu.Jiang	07.10.2020	HC.Qiu			

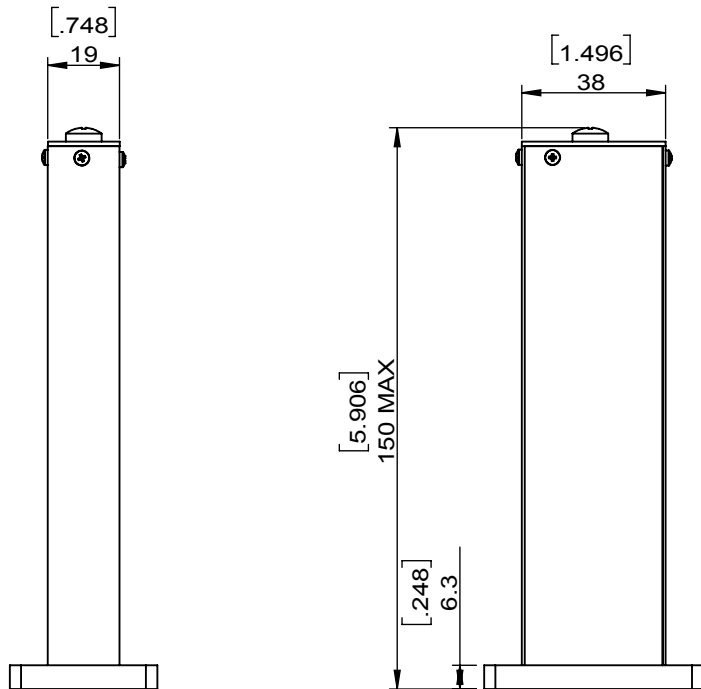

SPECIFICATIONS	
Part's Number	JAIWR137-6400T7100
Frequency(GHz)	6.400~7.100
Direction	
Insertion Loss(dB)MAX	
Isolation(dB)MIN	
Return Loss(dB)MIN	26.0
3rd IMD(dBc)MAX	-
Power FWD/REV/PK(Watt)	
Operating Temperature(°C)	-20~+60
Storage Temperature(°C)	-
2nd/3rd Harmonic(dBc)	-
Termination/Attenuator(Watt/dB)	-
Tab(W×LG×THK)(mm[Inch])	
Additional Notes	-

<b>JQL JQL Technologies Corporation</b>				
<b>MATERIAL:</b> Brass		<b>DWG NO:</b> JAIWR137-6400T7100		
<b>SURFACE TREATMENT:</b> Silver plating		DWG BY:	Hu.Jiang	07.10.2020
<b>DESCRIPTION:</b> waveguide termination		CHK'D BY:		SCALE
		APPV'D BY:		1:2
		Unit: mm[inch]	Tolerance: Liner: ±0.25 Anguar: ±0.5°	The First: 
				A4

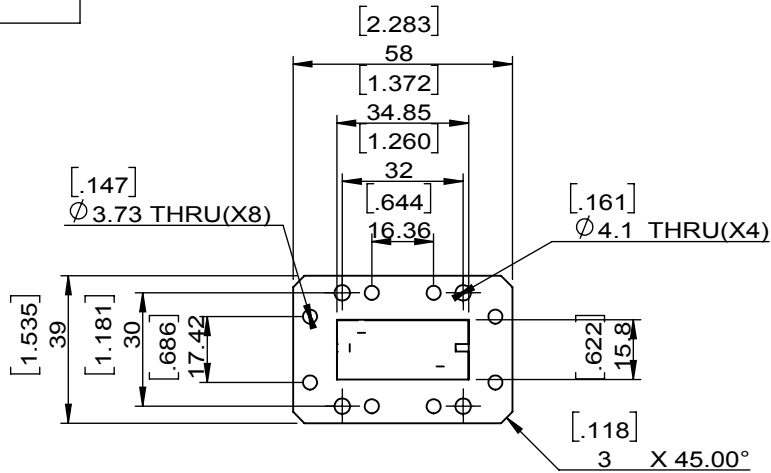

This document is the property of JQL Technologies Corporation. It cannot be copied, duplicated, used for manufacturing purposes or communicated to third party as a whole or partly, without the written consent of JQL Technologies Corporation.